

Planetary Mixer

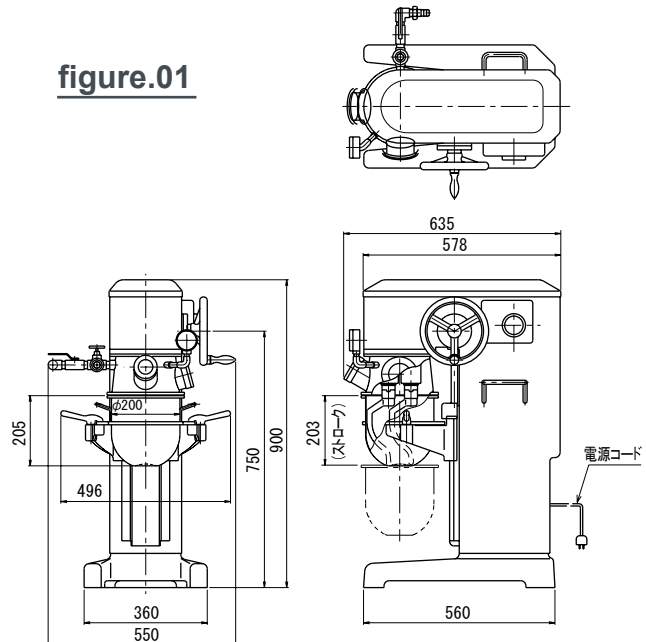

figure.01



Specification:

Model No. ACM-2LVTJ

- | | |
|--------------------------|---|
| 1) Power supply | AC100V, Single phase 3A / 0.3kw |
| 2) Stiring switch | Push button switches with overload protection |
| 3) Container elevation | Manual operation |
| 4) Capacity of Container | 2 liter (Approx. 67.62 fl oz) |
| 5) Effective capacity | Approx. 500ml to 1200ml (Approx. 16.90 to 40.57 fl oz) |
| 6) Container | SUS304, Internal surface - Hard chromium electroplating, buffing |
| 7) rpm | Rotation: 0 to 435rpm revolution: 0-142rpm
*The revoluton speed is approximately one third of the rotation speed. |
| 8) Drive | Variable speed drive |
| 9) Stir | Spiral hook stir: 2 peices (SCS13) - Hard chromium electroplating, buffing
Kneading Stir 1 peice |
| 10) The body color | Munsell 2.5 G 712 |
| 11) Weight | 140kg (Approx. 308lb) |
| 12) Dimension | 360mm(W) X 560mm(D) X 900mm (H) |
| 13) Viewing port | Installed (not possible to open) |

Options:

- *The vacuum pump unit is available for degas.
- *The cooling Jacket container is available for temperature control.
- *The various type of stirs, containers are available.